

# EXAMUNION

Certified IT Exam Material Authority



Accurate study guides, High passing rate!  
We offer free update service for one year!

<http://www.examunion.com>

**Exam : C1000-101**

**Title : IBM Cloud Professional  
Sales Engineer v1**

**Version : DEMO**

1.Which IBM Cloud offering enables clients to provision an isolated environment in the IBM Public Cloud?

- A. Secure Gateway
- B. Virtual Private Cloud
- C. Virtual Server for Classic
- D. Direct Link Dedicated on Classic

**Answer: B**

**Explanation:**

<https://www.ibm.com/cloud/learn/public-cloud>

2.Which component is represented by letter D in the displayed IBM VPC connectivity and security diagram?

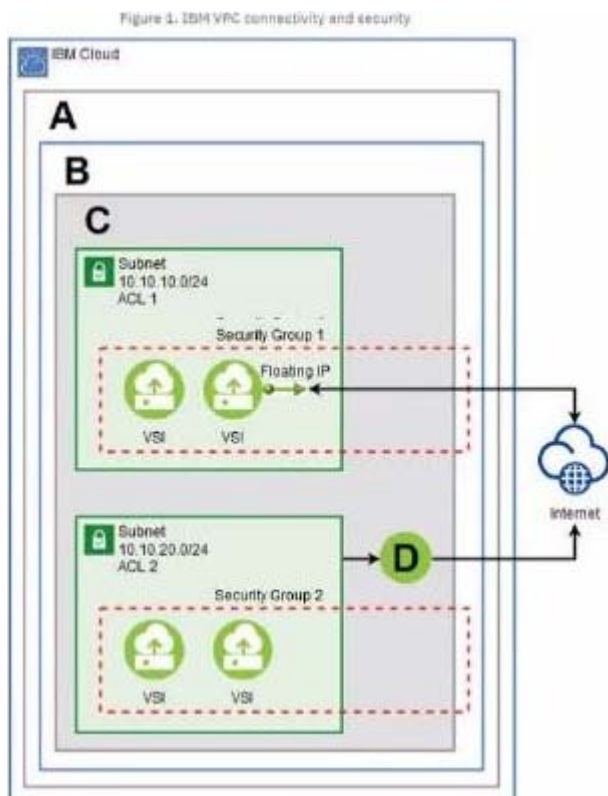

- A. direct link gateway
- B. transit gateway
- C. public gateway
- D. secure gateway

**Answer: A**

**Explanation:**

<https://www.ibm.com/cloud/architecture/content/course/advanced-networking-for-vpc/vpc-vs-classic-infra-structure/>

3.What is a true statement about workflows in the IBM Garage Method for Cloud?

- A. They define the entry points focused on client's goals.
- B. They include a prescriptive set of practices used to meet client's desired business outcome.
- C. They define an overall business goal and describe activities that client can implement to reach that

goal.

D. They leverage practices that are only pervasive throughout the workflow.

**Answer: A**

**Explanation:**

<https://www.ibm.com/cloud/architecture/content/course/explore-garage-methodology/>

4. After presenting a cloud native proof of concept, the customer was in agreement that the solution met the success criteria. However, the customer has not provided the final decision which they promised.

What Consultative Selling step should be used?

A. use the product as proof of the solution

B. follow-up with deadline discounts

C. follow-up with patience

D. follow-up by escalating

**Answer: A**

5. Which component is represented by the A in the image of the web application architecture?

Architecture

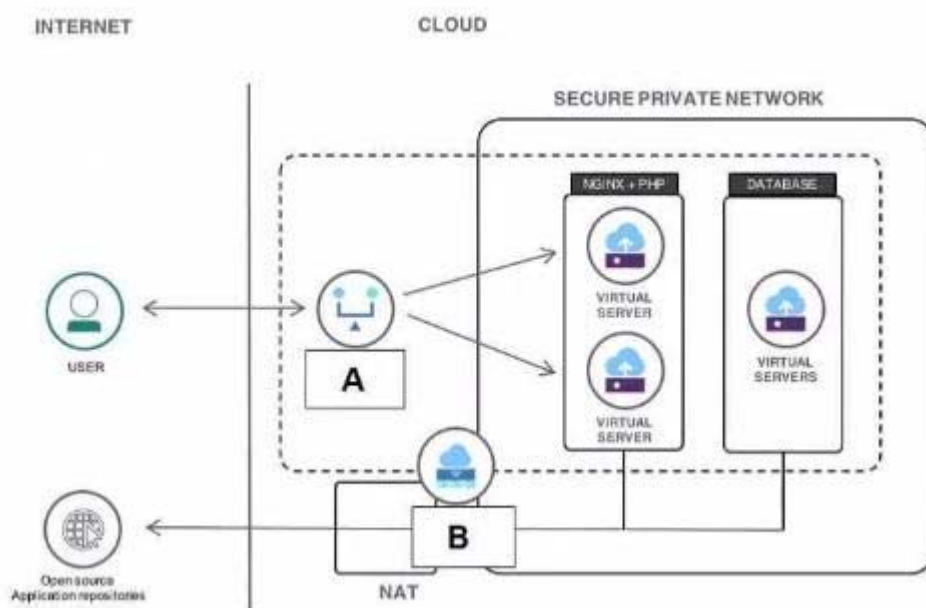

A. load balancer

B. firewall

C. container

D. cluster

**Answer: B**